

**MODEL RG-11
OPTICAL RAIN GAUGE**

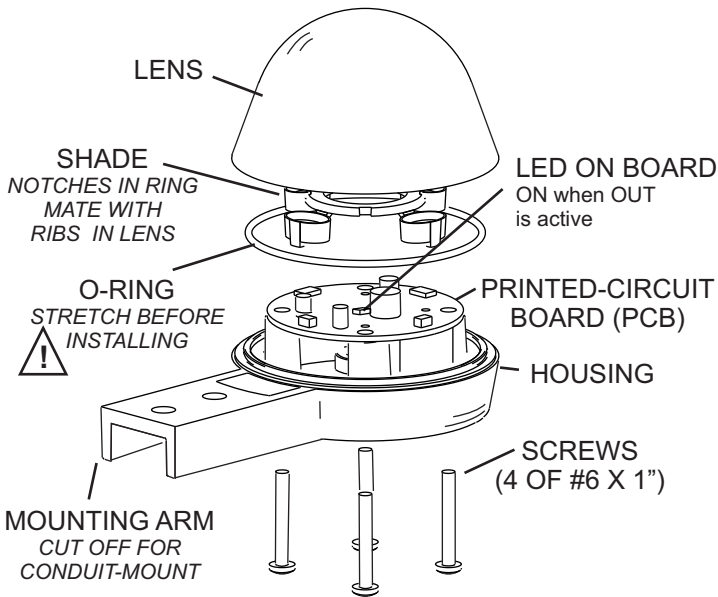

EXPLODED VIEW

INSTALLING THE RAIN SENSOR

1. Determine the Mode / Set DIP switches

You must set the DIP switches so that the RG-11 behaves the right way for your application. The pages that follow describe each of the possible modes, and how to set the DIP switches.

2. Mount the Rain Gauge

Mount the rain Gauge where it gets a clear measurement of precipitation— away from overhangs, etc.

The mounting arm is designed to fit over a strap 0.75" (19 mm) wide. Two 0.25" (holes 6.35 mm) are placed 0.75" (19 mm) apart.

The gland style connector goes in the bottom hole. Be sure to use wire rated for outdoor (high-UV) use.

For conduit applications, the mounting arm may be removed, and the wiring hole drilled out using a step drill to accommodate a 1/2" EMT compression connector or similar style of conduit connector.

3. Assemble the Rain Gauge as shown.

The silicone O-ring fits nicely in the lens groove, but it can fall or slip out during assembly. After the unit is assembled, verify that the O-ring is properly seated by confirming that you can see it through the lens, all the way around.

The Rain Gauge must be assembled when dry. Any water trapped inside can condense and cause corrosion. You may optionally add extra desiccant packets (not supplied). If the Rain Gauge is not subject to splashing or sprayed water, you may optionally vent the enclosure

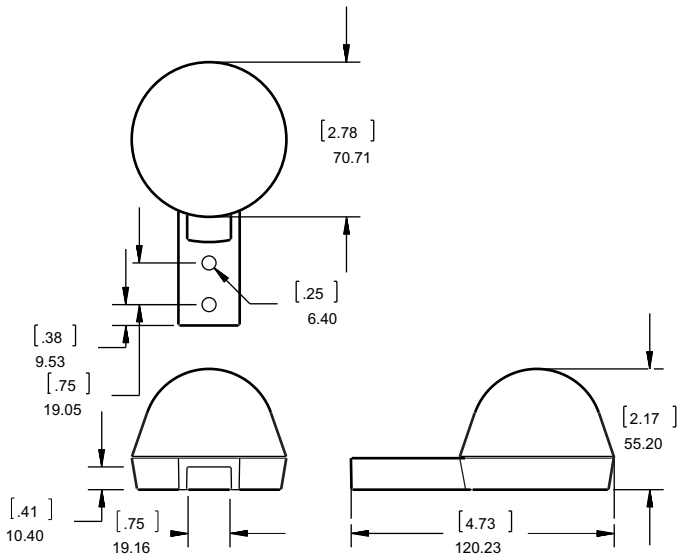

DIMENSIONAL VIEW



- APPLICATION WARNING -

Do not use the RG-11 in any application where the false indication of water or a missed valid detection of water could cause damage to life or property. It is the responsibility of the system designer / integrator to design redundancy into the system so that the failure of any one component, including the RG-11 or other sensor, does not result in disaster. The manufacturer of the RG-11, Hydreon Corporation, will in no way be liable for consequential damages due to the failure or false indication of one of its sensors.



HYDREON CORPORATION

RAIN GAUGE CONNECTIONS

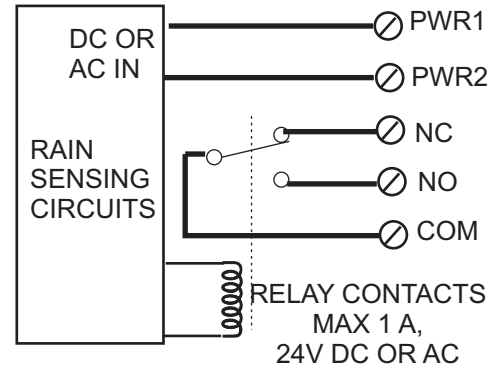
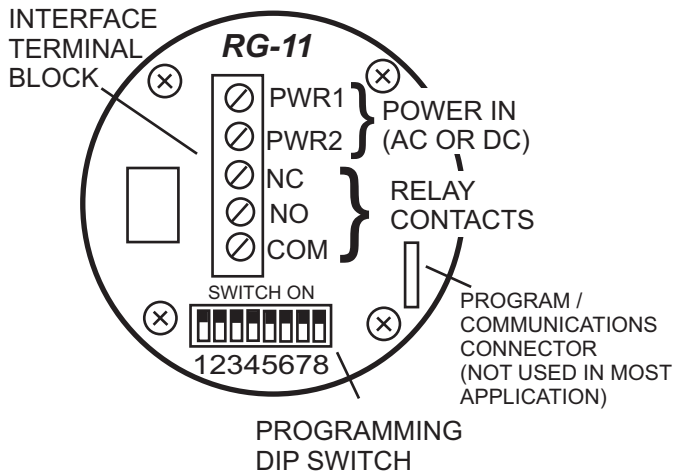

EQUIVALENT SCHEMATIC

RAIN GAUGE WIRING EXAMPLES

LINE VOLTAGE CONTROL "IT'S RAINING" APPLICATION

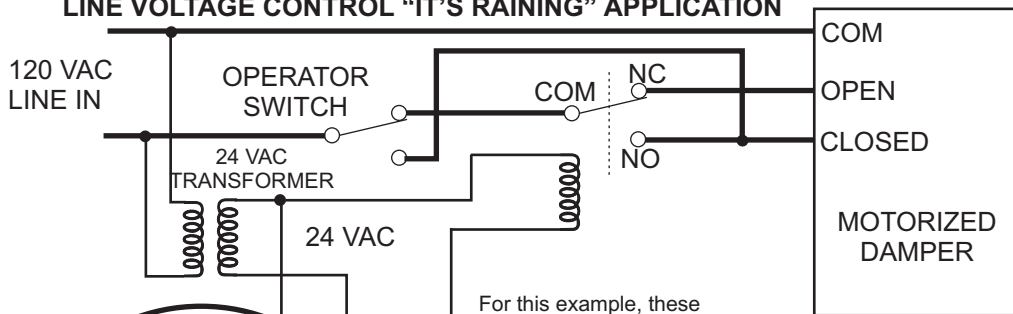

- The relay output of the RG-11 is rated for 24V AC or DC, at 1 A. Thus, the RG-11 cannot drive a line voltage (120 VAC) load without an external relay.

-The RG-11 requires a low voltage AC or DC supply and may not be directly powered from the 120 VAC line.

For this example, these switches are on:
 SW 5 - Sets the sensor to "It's Raining" mode.
 SW 3 - Monostable extend output for 15 minutes.

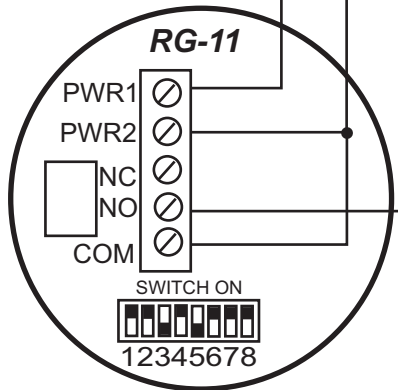

LOW VOLTAGE "IT'S RAINING" APPLICATION

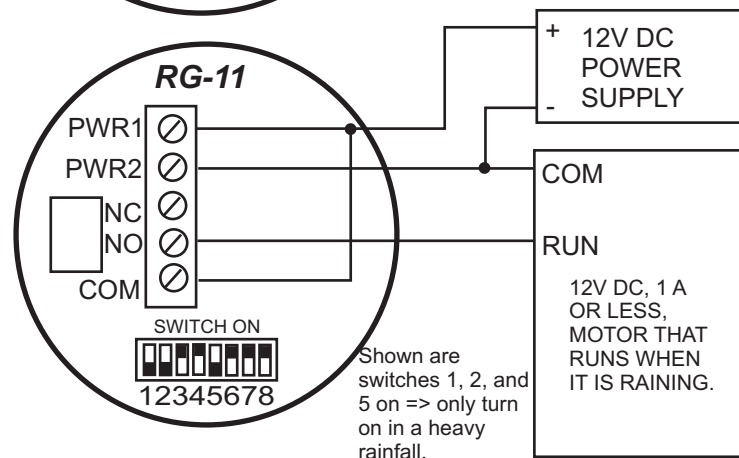

TIPPING BUCKET REPLACEMENT EXAMPLE

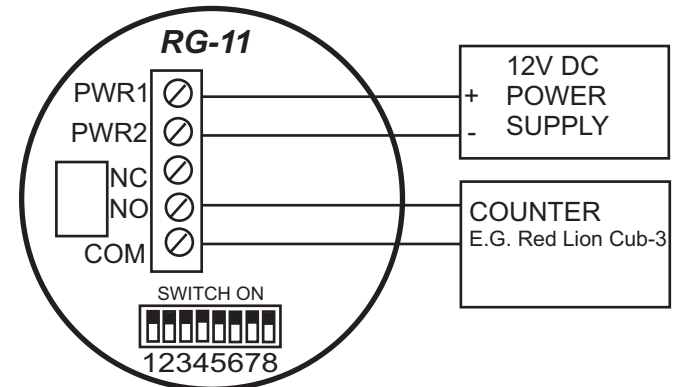

In many cases, the RG-11 may directly replace tipping buckets in existing systems. The switch settings shown here- all off- will emulate a tipping bucket of 0.01"

Specifications

Parameter	Value
Input Voltage	12 – 30VDC or 12 – 26 VAC 50V surge Reverse polarity protected to 50V
Current Drain	15 mA nominal. (No outputs on, not raining, no heater) about 1.5 mA in micro-power sleep mode. 50 mA with output on. 55 mA - With heater on, 24V dc input.
Output	Relay closure, Normally Open and Normally Closed contacts. Max load 1A, 24 VDC.
Operating Temperature range	-40 C to +60C

DIP Switches

Set the DIP switches for the application according to the tables below. Generally, a few switch positions (5, 6, and 7) set the overall mode of operation, and others (1, 2, 3, 4) adjust the behavior within the modes. **In the tables, 1 = Switch on, 0 = Switch off, X = switch in either position.**

Software Revision

This manual corresponds to software revision 016. The software revision is printed on a sticker place on the connector block. See www.rainsensors.com (click on "support") for information about differences in software revisions. Differences are generally minor.

Switch 8 is Enable Micro-power Sleep Mode in most applications.

Most applications will use SW 8 off. If micro-power is enabled, the low-power heater is disabled. In micro-power mode, if a long time (about 20 min) has elapsed since the last rain was detected, the unit will enter a less sensitive sleep mode. A large drop will cause it to exit sleep mode and resume normal operation. This is for battery or solar powered applications. Micro-power mode is disabled in Condensation sensing mode and in irrigation mode. Switch 8 must be off for First Flush Controller. The unit will not read the DIP switches during sleep.

OUT LED

The LED in the center of the circuit board turns on when OUT is on, as an aid to debugging.

Condensation

Generally, the RG-11 will sense condensation as if it were rainfall, but this seldom amounts to a significant accumulation of water. The built-in low power heater (DIP SW 8 off) will tend to reduce condensation.

Ambient Light Interference

The RG-11 is almost completely immune to the effects of ambient light, and may freely be mounted in direct sunlight.

Heater Notes

A built-in low power (0.25W) heater extends operation of the device to freezing (32 F or 0C). This is disabled if the micro-power (SW 8) is enabled. Note that this is a very modest amount of power; it will tend to drive off a modest amount of frost, but will not melt ice.

Dark Sensing

Turns output on when it is dusk-- nominally less than 2000 lux. This is for applications such as retracting sun-shields in the evening, when they are not needed. (Only in Mode 1, "It's Raining" applications.)

LED Flicker / Relay Buzz

If the relay and LED remain on for a long period of time (seconds), the LED may flicker, and the relay may make a barely audible buzz. This is because the RG-11 pulse-width modulates the relay drive signal to reduce current consumption. It does this to prevent excessive heat in the RG-11. This does not affect functionality in any way.

J2 Connector

J2 is a pin-field on 0.1" centers, used for programming, development, and testing of the RG-11. Most applications do not connect to J2, and we make this information available only for special applications.

Connector field is 0.025" square pins on 0.1" centers. An example compatible connector is Molex part number 22-01-3067. This is available from Digi-Key as part number WM2004-ND. The necessary crimp-on wire terminals are Molex 08-55-0131 / DigiKey WM4591-ND.

J2 Pin assignments

J2 - 1 GND
J2 - 2 +5V OUT
J2 - 3 SW4
J2 - 4 SW1
J2 - 5 SW2
J2 - 6 RS232 and SW 5.

Remote Switching

These connections may be used to remotely operate the corresponding switches, by grounding the connections. This can be used for operator-accessible sensitivity adjustment in wiper control applications.

RS-232 communications

Requires an external resistor. See the "support" link on www.rainsensors.com. Modes that require SW 5 on (It's Raining, Wiper Control and First Flush) cannot use RS-232.

Mode 0: Tipping Bucket							
Rain Gauge emulates a tipping bucket of the specified size.							
Switch							Behavior
7	6	5	4	3	2	1	
0	0	0	X	0	0	0	Bucket Size = 0.01"
				0	0	1	Bucket Size = 0.001" (Sensitive)
				0	1	0	Bucket Size = 0.0001" (Very sensitive)
				1	0	0	Bucket Size = 0.2 mm
				1	0	1	Bucket Size = 0.01 mm (sensitive)
				1	1	0	Bucket Size = 0.001 mm (Very sensitive)
				1	1	1	Reserved for system test

In tipping bucket mode, the Rain Gauge effectively emulates a tipping bucket of the specified size. For example, if the DIP switches are set to a tipping bucket mode with a bucket size of 0.01", then the output will pulse ON for 50mS each time 0.01" of water accumulates, just as a tipping bucket would. This can be externally totalized, and used to measure rainfall rates. Bucket sizes of 0.001" and 0.0001" are similar, generating pulses at accumulations of one one-thousandth, and one ten-thousands of an inch, respectively. These emulate what a tipping bucket would do if it were possible to make one that small. Metric bucket sizes are available as well, or the Inch unit scales may be scaled with external equipment.

Accuracy

We do not claim an accuracy spec for the RG-11. For more information see the "Tipping Bucket" link on www.rainsensors.com.

Mode 1: It's Raining							
Rain Gauge turns on the relay to indicate that it is raining when the rainfall has reached a given intensity.							
Switch							Function
7	6	5	4	3	2	1	
0	0	1	X	X	0	0	Very sensitive-- first detected raindrop.
					0	1	Sensitive-- turn on with very light rainfall (0.1" per hour).
					1	0	Medium Sensitivity-- turn on with medium rain (0.25" per hour. You would want your car's wipers on steady slow)
					1	1	Low Sensitivity-- turn on in heavy rainfall. (1" per hour. You would want your car's wipers on high)
			X	0	X	X	Output off when rain stops.
				1			Output Monostable Extended by 15 minutes
			0	X	X	X	No Dark-Detect - Normal operation
			1				Dark Detect

Use this mode to control equipment that should be controlled, enabled, open, closed, and so forth depending on whether or not it is raining. The output turns on when a given rate of rainfall is detected, and turns off after it has dropped below a threshold.

Each of the sensitivity levels (set by switches 1 and 2) provides different trip and release points. There is much hysteresis built in, but real rain fall rates typically fluctuate, even in what you may perceive as a "steady rain", so expect the output to turn on and off. The output will remain on for between about 30 seconds and 5 minutes after the last detected rain drop, depending on sensitivity setting and actual conditions.

Monostable Extend = Switch 3 ON

To prevent some piece of equipment from turning constantly on and off (or opening / closing, etc.) you can enable the Monostable extend (Switch 3). That will hold the output on for 15 minutes after the rain has ceased.

Dark Detect = Switch 4 ON

If this enabled, the output will also turn on when the ambient light drops below about 2000 lux. This feature may be used to retract a sun-shade awning when it is dark.

Mode 2: Condensation Sensor							
Rain Gauge detects condensation or frost formation on the surface.							
Switch							Behavior
7	6	5	4	3	2	1	
0	1	0	0	0	0	0	Very Sensitive- first sign of condensation
					0	1	Sensitive
					1	0	Medium Low
					1	1	Low

The rain sensor senses condensation by detecting a shift from the "clear" condition. The relay closes when the condensation occurs, and opens when the condensation goes away. The rain sensor is set to very gradually adapt the clear condition, so that very gradual build up of dirt or other contaminants do not cause a false trip.

Condensation sensing mode disables the heater and micro-power mode.

Mode 3: Wiper Control							
Rain sensing wiper control from off through intermittent and steady slow speeds.							
Switch							Behavior
7	6	5	4	3	2	1	
0	1	1	0	x	0	0	Normal Wiper Control
			0		0	1	Wipe More
			0		1	0	Wipe a Lot More
			0		1	1	Wipe a Whole Lot More
			1		0	0	Wipe Less
			1		0	1	Wipe a Lot Less
			1		1	0	Wipe a Whole Lot Less
			1		1	1	Wipe hardly at all
			x	0	x	x	Normal Slow Cycle Time (1.2 to 3 sec.)
				1			Long Slow Cycle Time (3 – 8 sec.)

See rainsensors.com for instructions that are just for wiper control applications. (Click on "Wiper Control").

The RG-11 may be used to control a wiper system. The output relay turns on when the slow motor winding should be engaged. This will typically be used to drive an external relay, which will, in turn, drive the wiper motor windings. This may be used for the wipers for a boat, ship, locomotive, observation window, or many other applications. The RG-11 does not care what the wipers are wiping.

WARNING: The relay contacts of the RG-11 can control only a 1A load, and wiper systems generally require many times that current. The RG-11 **MUST** be used with a suitable external relay in wiper control applications.

The nominal wiper control is set so that it properly controls the wipers of a passenger car. It is optimized for wiper systems that require between 1.2 and 3 seconds to make a single complete actuation of the wipers. A long cycle time is provide (Switch 4 on) for systems with a wiper actuation cycle time between 3 and 8 seconds. In all cases, the RG-11 provides a pulse to initiate the wiper actuation. Most wiper system will include some sort of cam feedback mechanism that causes the wipers to keep running until they reach a home position.

Mount the RG-11 so that it generally gets the same rainfall as the surface to be wiped. Usually, this means about a 45 degree angle. The RG-11 does not need to be within the actual field of view of the window. Adjust the sensitivity control DIP switches (3, 2, and 1) to set the system to wipe more or less, depending on the needs of the installation.

Mode 4: Irrigation Control								
Rain Gauge output on means inhibit watering.								
Switch							Behavior	
8	7	6	5	4	3	2	1	
X	1	0	X	X	0	0	0	Typical Water Control. Inhibit watering for up to 5 days.
					0	0	1	Water More
					0	1	0	Water a lot more
					1	0	0	Water Less
					1	0	1	Water a lot less
				0	X	X	X	Inhibit irrigation during a storm
				1				Allow irrigation during a storm
			0	X	X	X	X	Inhibit irrigation during freeze
			1					Allow irrigation during freeze
0								Normal Evaporation Rate
1								Hi Evaporation Rate

See rainsensors.com for instructions that are just for irrigation control applications. (Click on "Irrigation Control")

The RG-11 may be set to provide precise control of an irrigation system. Typically, the installation will connect to the COM and NC relay contacts to interrupt the valves when watering should be inhibited. Note that the RG-11 also requires 24 VAC (or other suitable supply.)

The nominal irrigation profile is set so that the ground receives an inch of water per week. It will inhibit watering upon the accumulation of 0.2 inches of water, and re-enable the system after that water has evaporated. This can be as short as less than a day, or as long as six days, depending on rainfall. Additional DIP switch settings are provided for allowing more or less watering, as shown in the table below.

Nominally (Switch 4 off), the RG-11 will inhibit watering during a storm, even if not much water has accumulated. The reasoning is that if it is raining hard now, the rainfall is likely to deliver enough accumulation to justify inhibiting at least the current cycle of watering. This prevents the "it's pouring, but my sprinklers are still running" objection from the customer, and the accompanying excessive runoff and muddy ground. The feature may be defeated by turning switch 4 on.

Normally, the RG-11 will inhibit irrigation if the temperature drops below freezing, or nominally about 34 degrees. If SW 5 is on, the RG-11 will allow irrigation below 34 degrees. Micro-power mode is disabled in irrigation control.

Evaporation Rate

Normal Evaporation Rate = 0.11 inches per day

Hi Evaporation Rate = 0.22 inches per day

In irrigation mode, if Switch 8 is on, the control assumes a high evaporation (or transpiration rate). Set this switch to ON for sandy soil or other conditions where the soil tends to dry out quickly. The system will re-enable the irrigation sooner.

Mode 6: Drop Detector							
Switch						Behavior	
7	6	5	4	3	2	1	
1	1	0	0	X	0	0	Normal drop threshold
					0	1	Sensitive Drop threshold. Expect rare false trips.
					1	0	Hi drop threshold. Trip only with large drops.
				0	X	X	One pulse per drop, longer pulses for bigger drops
				1			Multiple pulses per larger drop

The RG-11 may also provide drop detection. Use this if you want to do your own, external data interpretation. The output will pulse once with each detected drop. Normally, it will produce longer pulses (in multiples of 200 mS) for larger drops. If set to multiple pulses per drop (SW 3 ON), each detected drop will generate one or more 100 mS pulses, depending on drop size.

In sensitive mode, the threshold for drop detection is lowered to below the normal level. This makes the system more sensitive, but raises the possibility of false detections. It is up to the system designer to determine the proper tradeoff. Similarly, the Hi drop threshold will provide an output only for large drops, making false detections unlikely, for installations where a false detection is especially objectionable.

Mode 7: First Flush / Rain Water Harvest
 Rain Gauge output on means rain water is being harvested and first flush has occurred.

Switch								Behavior		
8	7	6	5	4	3	2	1	Level (in)	Gallons	Clean Time (days)
0	1	1	1	X	0	0	0	0.02	12	3
					0	0	1	0.04	25	5
					0	1	0	0.08	50	9
					0	1	1	0.16	100	13
					1	0	0	0.20	125	15
					1	0	1	0.24	150	17
					1	1	0	0.28	175	19
					1	1	1	0.32	200	21
					0	X	X	X	Normal Clean Time	
1				Gets Dirty Fast						

Note: Switch 8 must be off for this mode.

The RG-11 can be used in a Rain Water Harvest / First Flush application. In this mode, the RG-11 will not change the relay state until a certain amount of water has fallen. After a certain amount of water has been detected, the relay opens, diverting the water to a proper holding tank. So configured, the output relay acts as an "Enable Harvest" control, indicating that at least the desired amount of rainfall has accumulated.

Level
 The amount of water that will accumulate before the relay closes.

Gallons
 The number of gallons per thousand square feet of collected area that are diverted. Note that a conventional first flush diverter system totalizes water after it has made it through the collection system. The RG-11 enables the system as soon as the threshold has fallen, which may be substantially sooner. Take this into account when designing your system.

Clean Time
 After the rainstorm is over and the relay of the RG-11 is once again open, it will take some time for the collecting surface to become dirty again, and once again require a complete first flush. Clean time means how many days, after the water stopped, it takes for the system to require a full flush. Up to that time, the system will flush less. For example, a system is set to flush 0.08 of accumulation, and thus the clean time is 8 days. If a storm comes after only 4 days, the system will flush only half as much water before enabling harvest again.

Gets Dirty Fast = Switch 4 ON
 If switch 4 is on, the system remains enabled for only 12 hours after the rain storm stops. Also, the Clean Time is halved. Use this setting if the surface becomes contaminated especially quickly.

SAFETY, LIMITS OF RAIN GAUGE LIABILITY, AND WARRANTY

Only the rain sensor is covered-- absolutely no consequential damages. If this policy is unacceptable in your installation, do not use the RG-11.

It is the responsibility of the systems integrator and purchaser of the Rain Gauge to insure a safe installation. Any mechanical system, including one that incorporates a Rain Gauge, requires appropriate safety interlocks. Hydreon Corporation (Hydreon) warrants only the actual cost of the sensor, and only that it is free from defects in workmanship.

The Rain Gauge is warranted to be free from defects for a period of one year from date of purchase. Under no circumstances will Hydreon be liable for any consequential damages due to failure or any other mishap involving a Rain Gauge. Hydreon's liability in the event of a failure, or inability to sense a condition, is limited to the actual cost of the particular sensor. Explicitly, if other objects are destroyed due to water damage, or if any object is destroyed because of a false indication of water, Hydreon is in no way whatsoever liable for anything other than the cost of the Rain Gauge, and then only if the Rain Gauge is shown to have some defect in materials or workmanship. Limitations and imperfections of the Rain Gauge do not constitute a defect. Further, if some valuable data is not gathered because an erroneous indication of any sort due to the Rain Gauge, Hydreon is liable only for the cost of the Rain Gauge.

It is the responsibility of the system designer and purchasers of the Rain Gauge to insure that a failure of the Rain Gauge will not cause consequential damages. If a failure in Rain Gauge would cause disaster, we recommend against deployment of the Rain Gauge, or against the system in which the Rain Gauge is deployed. If a failure of a Rain Gauge would cause great expense, Hydreon recommends redundant Rain Gauges, and even in that case do not assume any liability for consequential damages. It is the responsibility of the system designer and purchasers of the Rain Gauge to be aware of performance limitations of the device. If a Rain Gauge fails for any reason Hydreon will not be responsible for the labor of servicing and or installing and/or removing the Rain Gauge. Labor is NOT COVERED. Hydreon recommends that the system designer perform a Failure-Mode Effects Analysis that includes the possibility of Rain Gauge failure. If a potential purchaser of the Rain Gauge does not agree with these terms, we ask that the potential purchaser not buy the Rain Gauge. Deployment of the Rain Gauge implies understanding and agreeing to these limits of liability.

Apply engineering judgment: Hydreon does not claim the RG-11 is a perfect rain sensor. It is what it is, and senses what it senses.

CASE and COSMETIC POLICY
 Some amount of yellowing or discoloration of the case is considered normal cosmetic aging of the device, and sensors so affect will not be replaced under warranty. Tiny cracks or crazing within the lens is also considered cosmetic, and units so affected will be replaced only if they are deemed by Hydreon corporation to be considered to be of a functional nature.