



**DAVIS** ®

## **SONIC-ANEMO-DZP**

**Ultrasonic wind vane-anemometer compatible with Davis Equipments**

### **User Manual**

11/10/2017 rev2.2

### **LCJ Capteurs**

ZA Le Chêne Ferré  
44120 VERTOU (France)

Tel: +33 (0)2 40 05 08 55

<http://www.lcjpgpteurs.com>

[contacts@lcjpgpteurs.com](mailto:contacts@lcjpgpteurs.com)

Copyright © LCJ Capteurs. All right reserved

No part of this manual can be copied in any form and by any means without prior written consent of LCJ Capteurs.

The products manufactured by LCJ Capteurs are constantly developed. Therefore, the content of this manual can be amended without notice.

This manual does not create any legal bond between LCJ CAPTEURS and the customer of final user and LCJ CAPTEURS does not assume any responsibility for any damage and/or injury resulting from the use of the product described in this manual.

Logos and images of Davis Instruments Corp. are used with their kind permission. Davis is a trade mark of Davis Instruments Corp. [www.davisnet.com](http://www.davisnet.com)

# SONIC-ANEMO-DZP

## ZERO-POWER ULTRASONIC WIND VANE / ANEMOMETER

Thank you for purchasing our SONIC-ANEMO-DZP sensor. This ultrasonic sensor is simple to use and does not require any external power supply thanks to its solar panel which allows full operation independently. The measurement rate of one per second gives you a clear vision of gusts.

### Quick Installation:

1-Connect the battery.



2-Push the cap in place.



3-Mount the sensor on a pole or a vertical surface

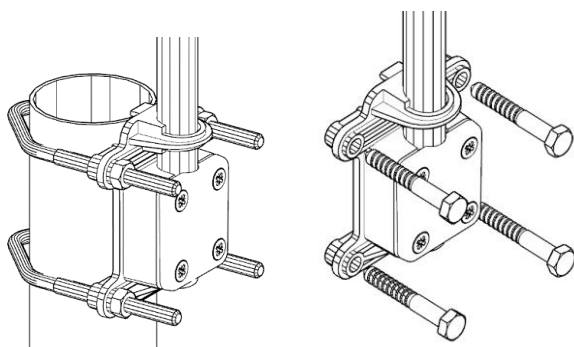

4-Align your sensor with the tool supplied.

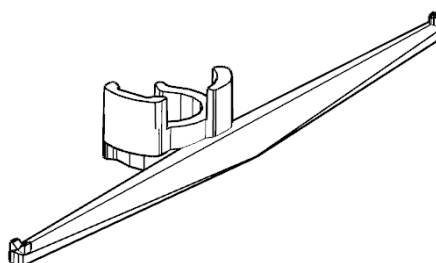

5-Connect the RJ11 connector to the interface module

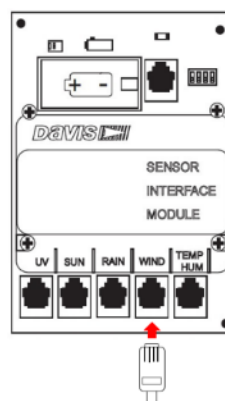

Photo credit  
DAVIS  
Instruments.

6-Your sensor is ready to use

### Battery capacity:

The SONIC-ANEMO-DZP operates independently thanks to its PV panel. The battery supplies sufficient voltage for 23 days without sun.

## Content

1. General information .....	1
1. About this manual .....	1
2. Warnings.....	1
3. Your experience.....	1
4. Safety .....	1
5. Recycling .....	2
6. Warranty.....	2
7. Product return .....	2
2. Introduction.....	3
3. Installation .....	4
1. Checking the delivery .....	4
2. Opening the box .....	4
3. Choose the best location .....	4
a) Clearance distance.....	4
b) Height of mounting.....	4
c) Alignment of the sensor .....	5
d) Mounting methods.....	5
4. Wiring .....	5
5. Power supply .....	6
6. Connection to the ISS Davis VP2.....	6
4. Configuration of the DAVIS VP2 .....	6
5. Commissioning.....	6
6. Maintenance.....	7
7. Replacing the battery .....	7
8. Technical specifications .....	7
9. Declaration of Conformity .....	8

## 1. General information

### 1. About this manual

This manual brings all the required information to install and use the SONIC-ANEMO-DZP for Davis VP2. Read all the information contained in this manual carefully before using the sensor, as misuse can cause mistakes and damage to the product.

### 2. Warnings

Important points are highlighted in this document as follow:



**Warning!** Serious hazard. Read carefully and follow the instructions. High risk of injury or even death.



**Warning:** Potential hazardous situation. Read carefully and follow the instructions to avoid damages on the product or loss of important data.



**Note:** Important information regarding use of the product.

### 3. Your experience

LCJ CAPTEURS values your feedback and suggestions to improve the manual. Should you find any mistake, please contact us indicating the chapter, section and page to correct. You can find our details on the manual's cover page and on our website: [www.ljcapteurs.com](http://www.ljcapteurs.com).

### 4. Safety

When using the product, safety measures described below must be followed to avoid damage and legal responsibility. Follow all safety and use instructions regarding the product. Follow all warning notices indicated in the product's use instructions. The following instructions are meant to reduce all risk of personal injuries, electric shock, fire and damage of the equipment.

Read carefully and follow all instructions contained in this manual to avoid measures errors caused by misuse.



**Warning!** Follow all safety measures applicable for the product's installation.

#### Electric safety measures

This product has been designed to be powered by a battery or a specific power supply. Any other power supply can be hazardous and will result in the product's nonconformity.

- Handle the battery with care.



This product contains a Lithium-ion iron phosphate battery (LiFePO<sub>4</sub>). There is a risk of fire if the battery is not correctly handled. Do not attempt to open or repair the battery. Do not dismount the battery, do not press on it, do not drill in it, do not place it in a short-circuit situation, do not throw it in fire or water and do not expose it to temperatures over 60°C (140°F). Use only original LiFePO<sub>4</sub> batteries with original connectors.

- Air transport.



When the product is transported by plane, it must be disconnected. Refer to IATA recommendations.

## 5. Recycling

LCJ Capteurs encourage recycling of all material when possible, following local regulations. You can find more details about recycling by contacting the local authorities in charge of Environment Protection in your country.

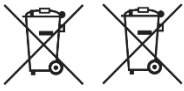

### **European Union (and European Economic Area) only.**

These pictograms indicate that the product cannot be disposed of with waste, according to the European Directive DEEE (2002/96/CE), the Directive applying to batteries disposal (2006/66/CE) and local waste regulations following these directives. When a chemical toxicity pictogram is printed below this one, according to the Directive applying to batteries disposal, it means that Heavy Metals are present (Hg = mercury, Cd = cadmium, Pb = lead) in the battery at or above the applicable cut-off concentration specified in the Directive. This product must be given to a disposal centre, i.e. when you purchase a new similar product, or to a designated collection point for the recycling of waste electrical and electronic equipment (EEE). Wrong behaviour in disposal can have consequences on the environment and human health, because of the potentially hazardous substances generally associated to electric and electronic equipment. Your contribution to a correct disposal of this product will contribute to efficient use of natural resources.

## 6. Warranty

Your LCJ CAPTEURS product is warranted against manufacturing defects in materials and workmanship for a period of 24 months from the date of purchase. LCJ CAPTEURS will at its discretion, repair or replace faulty products free of charge at their premises. The warranty does not cover the installation labour and shipping costs of the faulty parts. A proof of purchase can be asked when processing the warranty claim by written. Once LCJ CAPTEURS approve the warranty claim, the sensor must be sent to their workshop address. LCJ Capteurs guaranties that each wind sensor is tested and calibrated before despatch.

The warranty does not apply in the following cases:

1. Damage resulting from misuse.
2. Improper installation or inappropriate conditions of operation.
3. If the product has been damaged, open or repaired by an unapproved agent.
4. Damage resulting from lightning, fire or any similar circumstances.

Warranty is void if operation, use, installation and technical service instructions have not been followed and if a repair has been carried out without prior agreement.

## 7. Product return

Contact your dealer prior to returning a product to LCJ CAPTEURS. A Return Merchandise Authorisation (RMA) must be issued and received before sending a product back.

## 2. Introduction

A conventional Wind-vane Anemometer includes mechanical rotating parts. These parts are subject to wear and they represent sources of failure of the sensor. Our ultrasonic sensor has been designed to avoid this and to ensure reliable and stable operation. This Wind-vane-anemometer shows very stable results over a long term and with no maintenance.

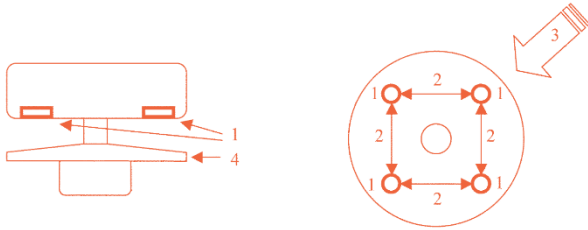

The sound (and ultrasound) is conveyed by the movement of the fluid in which it crosses. The electro acoustic transducers (1) communicate between themselves two by two using ultrasonic signals (2) to determine, following the orthogonal axes, the wave transit time differences induced by the air flow (3). The

measurements are combined in an integrated calculation to establish the wind speed and its direction in relation to a reference axis. The temperature measurements are used for calibration corrections. The sensor's design minimises the effect of heel angle (4). The CV7 range of products features lateral transducers delivering four independent measurements. The validity checks are used to measure head wind vectors for calculations. This method gives a sensitivity of 0.15 m/s, a 40 m/s (144 km/h) reliability and excellent linearity.\*

LCJ Capteurs has designed and manufactured wind sensors since 1999. Our range of wind vanes/anemometers covers the needs over many applications. They have proved their robustness and accuracy on the marine sector, and they are now widely used in other fields such as weather stations, industry, security and agriculture to name a few.

At LCJ Capteurs, each sensor is fully tested before despatch and the test results are saved against the serial number. The sensor is placed in our wind tunnel on a bracket that rotates through 9 degree steps. This is Computer Controlled. The sensor is aligned at 0 degrees of the air flow and then, 40 measure points are completed with data saved for speed and angle. You can read a typical test report here below. The full document is available on our website.

## 3. Installation

### 1. Checking the delivery

Before opening the box, check it carefully to spot any damage that can have occurred in transport. If the packaging is damaged, fill in a Freight Claim with full description of the problem.

### 2. Opening the box

Unpack the parcel in a dry and clean place and check the delivery:

1. SONIC-ANEMO-DZP with a 5 m cable.
2. Mounting bracket with 4 nuts.
3. Alignment tool
4. User manual



Warning: Unpack the product with care to avoid any damage

### 3. Choose the best location

The choice of the appropriate installation location is crucial to get the best measurements. The location must be free of turbulence and magnetic field resulting from electricity, engines, radio transmitters, radars, etc. For mobile installations, consider that the sensor measures the apparent wind speed and angle. This has to be integrated in the data process to calculate the true wind vector.

	<p><b>a) Clearance distance</b></p> <p>To avoid measurement errors the sensor must be installed at a distance of at least 10 times the height of the nearest obstacle.</p> <p>We recommend installing the sensor at a height of 3 metres in a clear environment and a minimum of 10 metres from nearby objects.</p>
	<p><b>b) Height of mounting</b></p> <p>When the sensor is installed on the top of a building roof, the installation height must be equal to the building's length or, if possible, 5 times the building's height.</p> <p>Install the sensor in the middle of the roof when possible. It is not recommended to install a sensor on a slanted roof. These roofs generate upwards turbulences that will affect the sensor.</p>



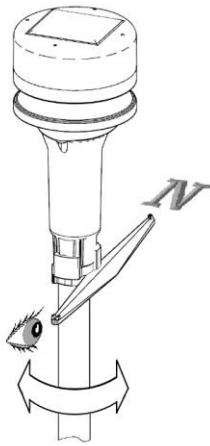

#### c) Alignment of the sensor

The sensor must be aligned to North. An alignment tool is supplied for this purpose. Clip the tool on the tube and slide it so that it snaps into the dedicated slots. Do not tamper with the slots. The tool must gently find its place. Slightly loosen the 4 screws that hold the tube. Align the tool - and the sensor - to North. Tighten the screws.



Note: Magnetic deviation must be considered to reference the measurements to True North.

#### d) Mounting methods

The SONIC-ANEMO-DZP comes with a mounting bracket allowing two mounting methods:

On a pole:

Pole diameter:  $\varnothing$  35 mini ;  $\varnothing$  48 maxi.

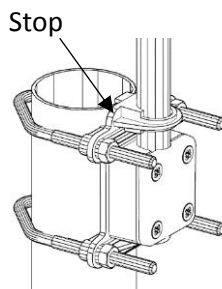

Max. tightening torque: 1.5 N.m

On a vertical surface:

(the sleeper screws are not supplied)

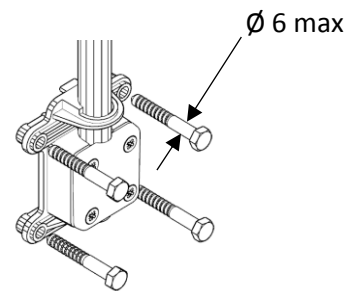

## 4. Wiring

The SONIC-ANEMO-DZP includes a data cable with a RJ11 connector to connect to the VP2 Interface and 2 pairs of wires with connectors for the battery connection.





## 5. Power supply

The PV panel ensures the SONIC-ANEMO-DZP operates independently. The energy is stored in a LiFePO4 battery of 3.2 V – 600 fitted in a 14500 box.

## 6. Connection to the ISS Davis VP2

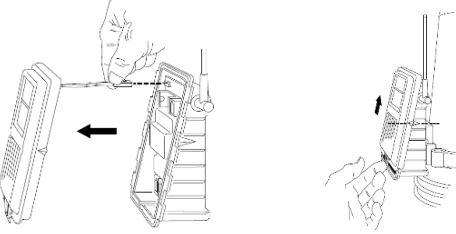
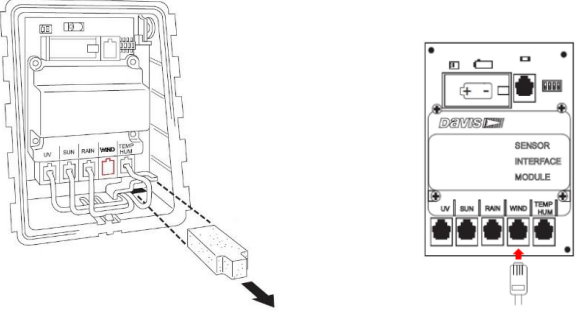
Follow the following instructions to connect the SONIC-ANEMO-DZP to a ISS Davis VP2 :

	<p>a)- Open the SIM box, sliding the cover upwards. b)- Disconnect the Solar Module if it is fitted.</p>
	<p>c)- Take out the cap to insert the SONIC-ANEMO-DZP's RJ11. d)- Connect on the "WIND" socket. e)- Connect the Solar Module back if required. f)- Put the cap and the cover back in place.</p>
<p> Note: Refer to your DAVIS VP2 for more information about the Interface Module. <i>Photos credit DAVIS Instruments.</i></p>	

## 4. Configuration of the DAVIS VP2

The anemometer cups must be set to "OTHER" in the Setup Menu.

## 5. Commissioning

For a correct start, the PV module must supply at the minimum energy comparable to 50 W/m<sup>2</sup> solar energy.

The battery is disconnected for delivery.

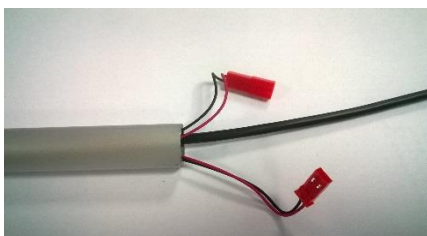

Disconnected battery



Connected battery

It is recommended to complete the wiring of your installation before connecting the battery.

Then, insert the connectors inside the tube and plug the cap in place.

After one minute of initialisation and with enough sun exposure, your SONIC-ANEMO-DZP is ready to operate.

## 6. Maintenance

The SONIC-ANEMO-DZP does not require particular maintenance. Wipe eventually the solar module from time to time.



Warning: Do not use alcohol base cleaning products. Use a clean soft cloth, clear water or a neutral cleaning product.

## 7. Replacing the battery

Choose a clean and dry location to change the battery.

- a)- Disconnect the RJ11 from the SIM.
- b)- Dismount the SONIC-ANEMO-DZP.
- c)- Open the tube.
- d)- Pull the battery's wires.
- e)- Disconnect the battery.
- f)- Spot the North mark on the battery's box.
- g)- Unscrew the 3 screws of the battery's box:



- h)- Slide the tube along the cable to access the battery.
- i)- Pull the battery out with the wires and connectors.
- j)- Insert the wires and connectors of the new battery until they come out of the other side of the tube.
- k)- Put the new battery in place.
- l)- Slide the tube back to the slot while taking care of the North mark previously identified.
- m)- Tighten the 3 screws.
- n)- Connect the battery.
- o)- Insert the wires and the connector in the tube and plug the cap.
- p)- Mount the SONIC-ANEMO-DZP back in place.
- q)- Connect the RJ11 on the SIM.

Note: When purchasing the battery at LCJ Capteurs, please mention the part number: DZP\_BATT.



Use only original battery with its wires and connectors.  
Do not weld the wires directly on the battery.

## 8. Technical specifications

Technical documentation is available upon request.

## 9. Declaration of Conformity

**LCJ Capteurs certifies that the following product:**

SONIC-ANEMO-DZP, Ultrasonic Wind-vane-anemometer

Conforms with the provisions of the following directives:

1. Electromagnetic Compatibility: 2004/108 / CE
2. Low voltage: 2006/95 / CE

This declaration of conformity is based on the product's compliance with the following harmonised standards:

1. Electromagnetic Compatibility: EN 61326-1: 2006
2. Safety: EN 61010-1: 2001

Date of issue: 14/10/2016

Signed by:

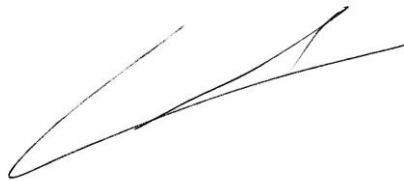

Christophe MICHEL

Title: CEO